

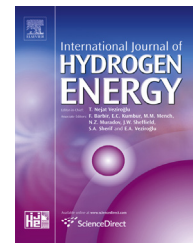

ELSEVIER

Available online at [www.sciencedirect.com](http://www.sciencedirect.com)

ScienceDirect

journal homepage: [www.elsevier.com/locate/ijhe](http://www.elsevier.com/locate/ijhe)

## An adaptive fuzzy logic controller (AFLC) for PEMFC fuel cell

Nedjem Eddine Benchouia <sup>a,\*</sup>, Abdallah Derghal <sup>b</sup>, Bouziane Mahmah <sup>c</sup>,  
Belgacem Madi <sup>a</sup>, Lakhdar Khochemane <sup>a</sup>, Elias Hadjadj Aoul <sup>d</sup>

<sup>a</sup> Département Génie Mécanique, Faculté de Technologie, Université 20Aout1955, P.O.Box.26 Route d'El-Hadiek, Skikda, Algeria

<sup>b</sup> Département Génie électrique, Faculté des sciences et sciences appliquées, Université Larbi Ben M'hidi, BP358, Oum el Boughi, Algeria

<sup>c</sup> Division Hydrogène Énergies Renouvelables, Centre de Développement des Énergies Renouvelables, CDER, BP 62 Route de l'Observatoire Bouzaréah, 16340 Algiers, Algeria

<sup>d</sup> Département Electromécanique, Faculté de Technologie, Université Badji Mokhtar, P.O. Box. 12, Annaba, Algeria

### ARTICLE INFO

#### Article history:

Received 31 January 2015

Received in revised form

28 May 2015

Accepted 29 May 2015

Available online xxx

#### Keywords:

PEMFC fuel cell

Gases flow rate

Fuzzy logic controller

PID controller

Matlab/Simulink

### ABSTRACT

Among the various fuel cell technologies available for use in vehicular systems, the Proton Exchange Membrane Fuel Cell (PEMFC) has drawn the most attention due to its simplicity, viability, higher power density and operation at lower temperatures. Due to this features, PEMFC is considered to be the most suitable technology for vehicular systems, industry and other applications.

As fuel cells are likely to be used in many future applications, great efforts have recently been made for their comprehension and design. This paper focuses on a 1.2 W PEM fuel cell unit and develops the models of stack voltage and stack power. While PEM fuel cell is a nonlinear process, it is very suitable to use fuzzy control to solve the control issue of the fuel cell. The stack output power can be controlled to a given value by using a variable universe fuzzy controller by controlling input gases flow rate.

In this paper a FLC controller have been designed to control the voltage of at the presence of fluctuations. The results of implementation of this designed FLC controller on a dynamic electrochemical model of a small size 1.2 W, PEM fuel cell have been simulated by MATLAB SIMULINK and compared with a traditional PID controller. Simulation results show that good control effects can be achieved by using the adaptive fuzzy control system.

Copyright © 2015, Hydrogen Energy Publications, LLC. Published by Elsevier Ltd. All rights reserved.

### Introduction

Fuel cells are considered a very appealing replacement for energy systems run on fossil fuels, largely due to the fact that

they are extremely environmentally friendly with no toxic byproducts because the fuel, hydrogen, is a clean fuel [20]. A fuel cell is an electrochemical device that produces electricity using hydrogen and oxygen through electrochemical reactions [21].

\* Corresponding author. Tel.: +213 771 953 410; fax: +213 37 37 60 37.

E-mail address: [nedjemo41@yahoo.fr](mailto:nedjemo41@yahoo.fr) (N.E. Benchouia).

<http://dx.doi.org/10.1016/j.ijhydene.2015.05.189>

0360-3199/Copyright © 2015, Hydrogen Energy Publications, LLC. Published by Elsevier Ltd. All rights reserved.

Fuel cells differ from batteries in that they do not need recharging, they operate quietly and efficiently, and when hydrogen is used as fuel they generate only electric power and drinking water. So, they are called zero emission engines. The research and application of proton exchange membrane has attracted more and more attentions [5] due to the following reasons: lower operation temperature, thus they can be rapidly turned on and off; lower operation pressure, hence greater safety; they can be easily set into mode system; they have lower emission ratio and higher conversion ratio [1,4] and it is one of the promising technologies for power generation in future [2].

Many researches in the performance of PEMFC have been done, and significant improvements have been achieved in PEMFC technology, such as in the fields of operating temperatures both fuel cell and humidifiers, pressure, flow rates and relative humidity of fuel and oxidant gases [22]. However, the performance, reliability, cost and stability for the present PEMFC technology are not enough to replace internal combustion engines. Thereby comprehensively considering above fundamental problems, fuel cells have to be improved their performance and be reduced their cost in order to achieve best performance [23].

The PEMFC needs to be controlled rapidly and efficiently in correct operating conditions. One of the significant challenges in control algorithms is that many parameters such as operating temperatures, pressure and flow rates of fuel and oxidant gases and so on affect the performance of PEMFC [3]. However, fuel cell output voltage is changed in different loads. In order to keep constant cell's voltage, it is vital to use a controller.

Maintaining a fuel cell system in correct operating conditions when subjected to fast load changes requires good system control. The complex and nonlinear dynamics of the fuel cell make it a difficult task to design a good control system. Fuzzy logic control is considered to be a useful tool for non model based control system design [24]. The techniques of fuzzy logic control have been used in many applications successfully [25,26]. It is an effective method to solve complex industrial process control.

Many researchers have devoted themselves to the dynamic modeling and control of fuel cells. While PEM fuel cell is a nonlinear process, it is very suitable to use fuzzy control to solve the control issue of the fuel cell. Fuzzy inference methods have been implemented in the temperature [14] and power [15,16] control of the fuel cell system. However, there is often a conflict between the fine control and the real-time control. Well control needs to add more control rules thus increase the calculation burden. For example, Kisacikoglu et al. [15] integrate a fuel logic control algorithm into the power conditioning unit and they have used 80 fuzzy inference rules; Sakhare et al. [16] design a fuzzy controller of fuel cell for stand alone and grid connection and they have used 49 fuzzy inference rules; Erdinc et al. [17] presented a new wavelet-fuzzy logic based load sharing and control algorithm is implemented for the dynamic PEMFC/UC hybrid vehicular power system model. Besides, an experimentally verified dynamic UC model is utilized in the developed model.

On the other hand, fuzzy logic controller has attracted the attention of researchers because it can deal with nonlinear

systems and does not need precise mathematical modelling of the system [5]. Compared with conventional PI controller, fuzzy logic controller has the potential to provide an improved performance even for a system with wide parameter variations [6]. The fuzzy logic controller has advantages of robust, simple, easily to be modified, usable for multi input and output sources, and to be implemented very quickly and cheaply.

In this paper, a dynamic system of PEMFC fuel cell is modeled and an adaptive fuzzy controller is designed to control the PEMFC system to maintain a constant output voltage. In this framework, a robust controller is developed to regulate the input hydrogen and oxygen of PEMFC.

The paper is organized as follows: Section 2 presents the dynamic model of the PEMFC fuel cell. The proposed control structure is addressed in Section 3. Here PEMFC hydrogen molar flow controller based on fuzzy logic is implemented. To demonstrate the effectiveness of the proposed strategy, simulation results are presented in Section 4; and finally, in Section 5, conclusions are given.

## PEMFC fuel cell model

In order to study the dynamic model of Fuel Cell, schematic and structure as well as performance of fuel cell must be considered. A general fuel cell schematic system is shown in Fig. 1. The origin of power in PEMFC can be understood by considering the chemical reactions occurring at cathode and anode compartments given as follows:

### Anode reaction

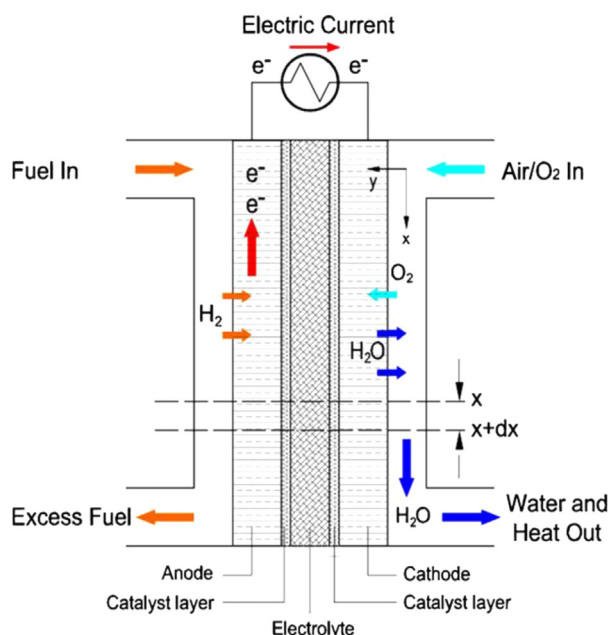
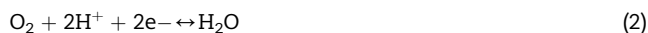

Fig. 1 – Schematic diagram of fuel cell.

**Cathode reaction****Total cell reaction**

The products of this process are water, DC electricity and heat.

The model of fuel cell used in this study is based on the dynamic Proton Exchange Membrane Fuel cell (PEMFC) development in Refs. [7], [8]. This model is based on simulating the relationship between output voltage and partial pressure of hydrogen, oxygen. The relationship between the modular flows of any gas through the valve is proportional to its partial pressure inside the channel [9]. For hydrogen, this relationship can be expressed as follows

$$\frac{q_{\text{H}_2}}{p_{\text{H}_2}} = \frac{k_{\text{an}}}{\sqrt{M_{\text{H}_2}}} = k_{\text{H}_2} \quad (4)$$

With,  $p_{\text{H}_2}$  hydrogen partial pressure (atm),  $k_{\text{an}}$  anode valve constant ( $\text{Kmol Kg (atm s)}^{-1}$ ),  $M_{\text{H}_2}$  molar mass of hydrogen ( $\text{kg kmol}^{-1}$ ),  $k_{\text{H}_2}$  hydrogen valve molar constant ( $\text{kmol (atm s)}^{-1}$ ).

Finally, for hydrogen molar flow, there are three significant factors which are hydrogen input flow, hydrogen output flow, and hydrogen flow during the reaction [7]. Relation between these three factors is:

$$\frac{d}{dt}(p_{\text{H}_2}) = \frac{RT}{V_{\text{an}}}(q_{\text{H}_2}^{\text{in}} - q_{\text{H}_2}^{\text{out}} - q_{\text{H}_2}^r) \quad (5)$$

With,  $R$  universal gas constant ( $(1 \text{ atm})/(\text{kmol K})$ ),  $T$  absolute temperature (K),  $V_{\text{an}}$  volume of the anode ( $\ell$ ),  $q_{\text{H}_2}^{\text{out}}$  hydrogen output flow ( $\text{kmol s}^{-1}$ ),  $q_{\text{H}_2}^{\text{in}}$  hydrogen input flow ( $\text{kmol s}^{-1}$ ),  $q_{\text{H}_2}^r$  hydrogen flow that reacts ( $\text{kmol s}^{-1}$ ).

According to the basic electrochemical relationship between the hydrogen flow and the FC system current, the flow rate of reacted hydrogen is given by Refs. [7,10]:

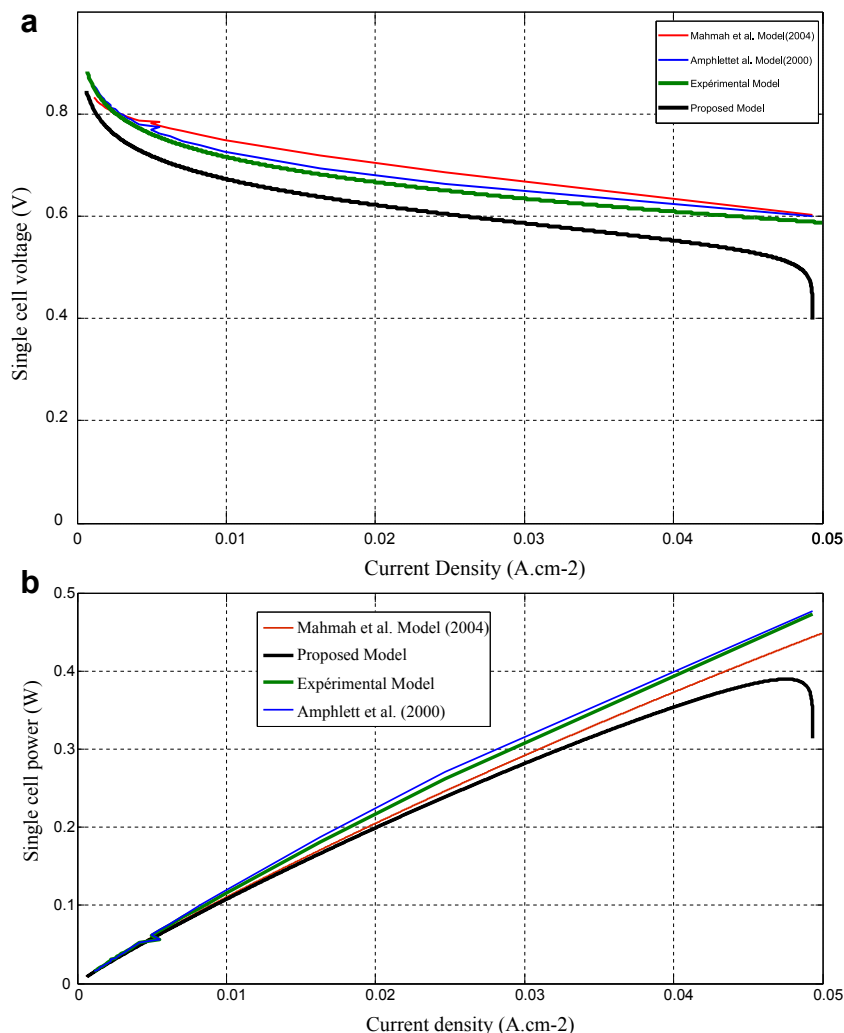

**Fig. 2 – a.b – P/J and V/J characteristics of PEM fuel cell at  $T = 298.5 \text{ K}$ .**

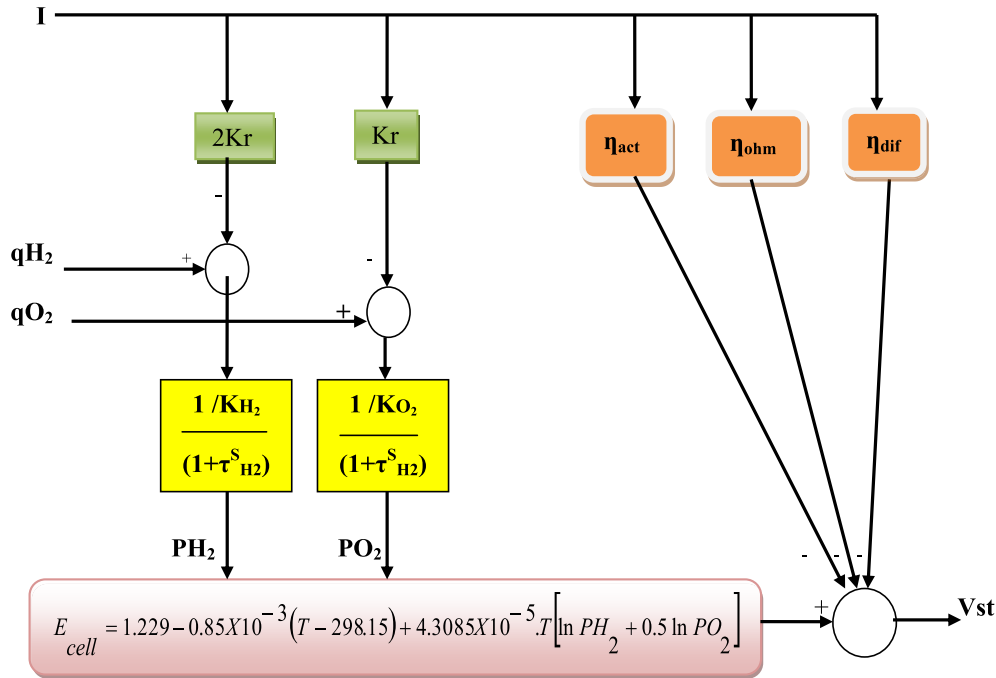

Fig. 3 – PEMFC Fuel cell dynamic model.

$$qH_2^i = \frac{NI}{2F} = 2K_r I \quad (6)$$

Where  $K_r$  is a modeling parameter constant ( $\text{kmol} (\text{sA})^{-1}$ ). Which has a value of  $\frac{N}{4F}$ .

The molar flow of hydrogen that reacts can be found from the basic electrochemical relationship between hydrogen flow and the fuel cell system current [10].

The partial pressure of the flow of hydrogen is determined by the following differential equation: [8].

$$pH_2 = \frac{1/K_{H_2}}{(1 + \tau_{H_2}^s)} (q_{H_2}^{in} - 2K_r I) \quad (7)$$

Where:

$$\tau_{H_2} = \frac{V_{an}}{RTK_{H_2}} \quad (8)$$

$$qH_2^{in} = \frac{2K_r}{U_{opt}} \left( \frac{1}{1 + \tau_f^s} \right) \quad (9)$$

Similar operation can be done oxygen partial pressure [13].

The Nernst's equation and Ohm's law determine the average voltage magnitude of the fuel cell stack [7] [27]. The following equations model the voltage of the fuel cell stack:

$$V_{stack} = N_{cell} \cdot V_{cell} = N_{cell} (E_{cell} - \eta_{act} - \eta_{ohm} - \eta_{conc}) \quad (10)$$

$$E_{cell} = 1,229 - 0,85 \cdot 10^{-3} (T - 298,15) + 4,3085 \cdot 10^{-5} \cdot T [\ln PH_2 + 0,5 \ln PO_2] \quad (11)$$

$$\eta_{act} = \xi_1 + \xi_2 T + \xi_3 T \ln(CO_2) + \xi_4 \cdot T \ln(I) \quad (12)$$

$$\eta_{ohm} = I(R_m + R_c) \quad (13)$$

Table 1 – Main parameters of PEMFC [8].

Parameters	Value	Unit	Parameters	Value	Unit
T	298.15	K	$R_m$	0.126	S
F	96487	C/mol	C	3F	$\Omega$
R	8.314	J/(kmol K)	$R_c$	0.0003	$\Omega$
$E^0$	1.229	V	B	0.016	V
N	4		$r_{H-O}$	1.168	/
$K_r$	$1.0364 \times 10^{-5}$	kmol/(s A)	L	230	$\mu\text{m}$
$U_{opt}$	0.85		$\xi_1^{theorique}$	-0.949	V
$K_{H_2}$	$4.22 \times 10^{-5}$		$\xi_1^{experimental}$	-1.053	V
$K_{O_2}$	$2.11 \times 10^{-5}$	kmol/(satm)	$\xi_2$	$0.02866 \ln(A) + 4.3 \times 10^{-5} \ln(CH_2)$	
$\tau_{H_2}$	3.37	kmol/(satm)	$\xi_3$	$7.6 \times 10^{-5}$	
$\tau_{O_2}$	6.74	S	$\xi_4$	$1.93 \times 10^{-4}$	
$\tau_f$	0.8	S	$J_{lim}$	0.0496	A/cm <sup>2</sup>
C	3F	$\Omega$	$\psi$	14	

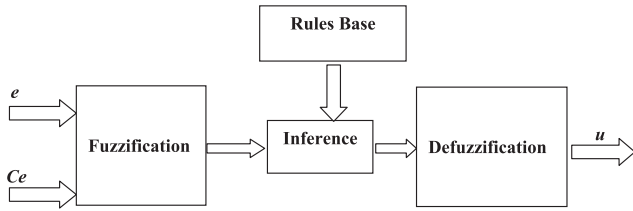

Fig. 4 – General diagram of a fuzzy controller.

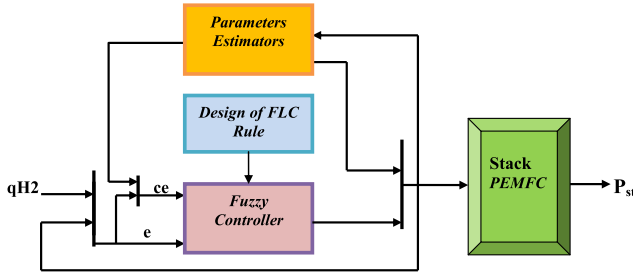

Fig. 5 – Block of Fuzzy controller.

$$\eta_{con} = -B \ln\left(1 - \frac{I}{I_{lim}}\right) \quad (14)$$

The instantaneous electrical power supplied by the cell to the load can be determined by the equation:

$$p_{fc} = I \cdot V_{stack} \quad (15)$$

where  $V_{stack}$  is the cell output voltage for each operating condition, and  $P_{fc}$  is the output power.

Fig. 2.a shows the result of output voltage and output power against load current at steady state for operating temperature 298.15 K. The V–I characteristic curve experiment is conducted and the proposed model is simulated for comparison as shown in Fig. 2a and b shows the power increases gradually to the maximum power point and then decreases. The maximum power produced by this model of fuel cell is 0.39 W, when the load current is 0.07895A and the voltage output is 0.54 V. There is a small difference between the experiment data and the simulated data [28] at a low current, because of the nonlinear behaviours of a fuel cell.

This model is presented in Fig. 3 and the parameters are given in Table 1 [8].

### Design of PEMFC fuzzy logic controller (FLC)

The Fuzzy logic controller uses the fuzzy logics to make the decisions and to control the output of the controller. The fuzzy controller consists of five different steps and parts, including definition of input–output variables of the controller, fuzzification, designing of fuzzy control rules, inference and defuzzification [15,16] as shown in Fig. 4.

The power flow from the PEMFC to the load is controlled though controlling the flow of hydrogen. The proposed fuzzy logic controller controls the active power by controlling the hydrogen flow [11]. Fig. 5 shows the structure of the closed-loop fuzzy control system. A fuzzy control system with dual

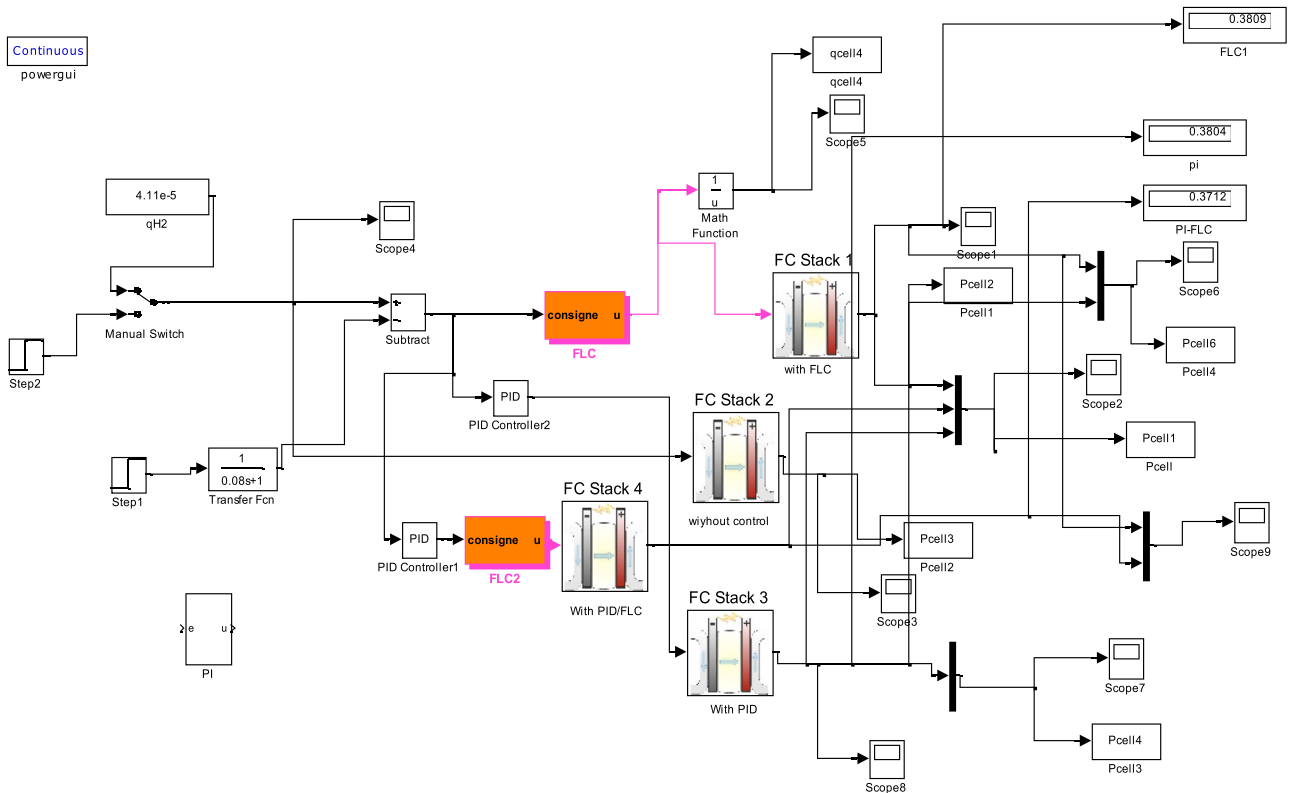

Fig. 6 – Fuzzy logic-PID block diagram of PEMFC fuel cell/MATLAB/Simulink.



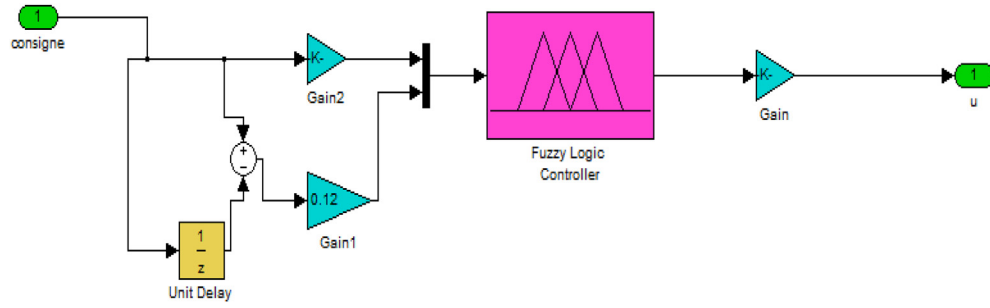

Fig. 8 – FLC architecture.

inputs is used to control the output power of the fuel cell, in this case the controller is FLC having inputs the error  $e(k)$  and change of error  $ce(k)$ . The output of the controller is the duty ratio of the hydrogen flow  $u_{H_2}(k)$ . The error, change of error and output of the controller are given.

$$e(k) = q_{H_2} - q_{H_{2b}} \tag{16}$$

$$ce(k) = e(k) - e(k - 1) \tag{17}$$

$$u_{H_2}(k) = u_{H_2}(k - 1) + \Delta u_{H_2}(k) \tag{18}$$

Where  $q_{H_2}$  is the flow hydrogen from the current feedback signal were is proportional to the load,  $q_{H_{2b}}$  is the hydrogen

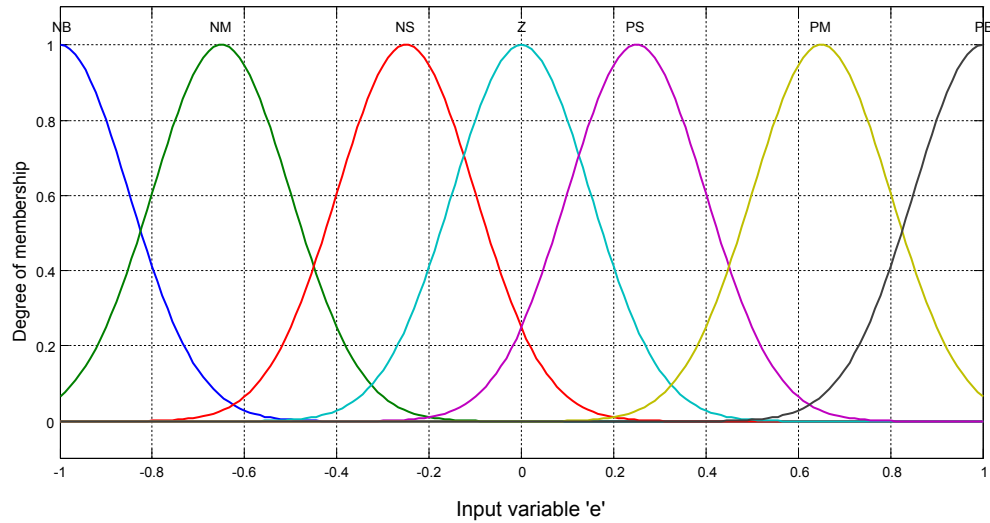

Fig. 9 – Membership functions of the error e.

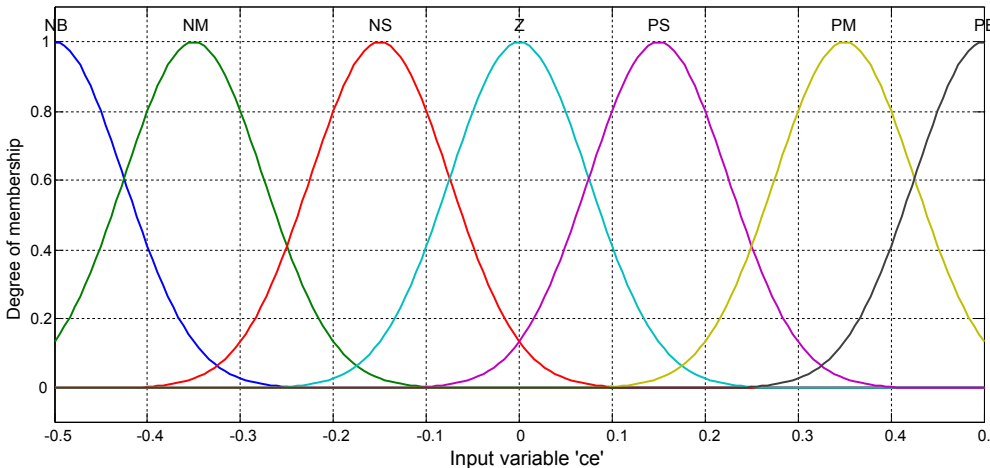

Fig. 10 – Membership function of the change of error ce.

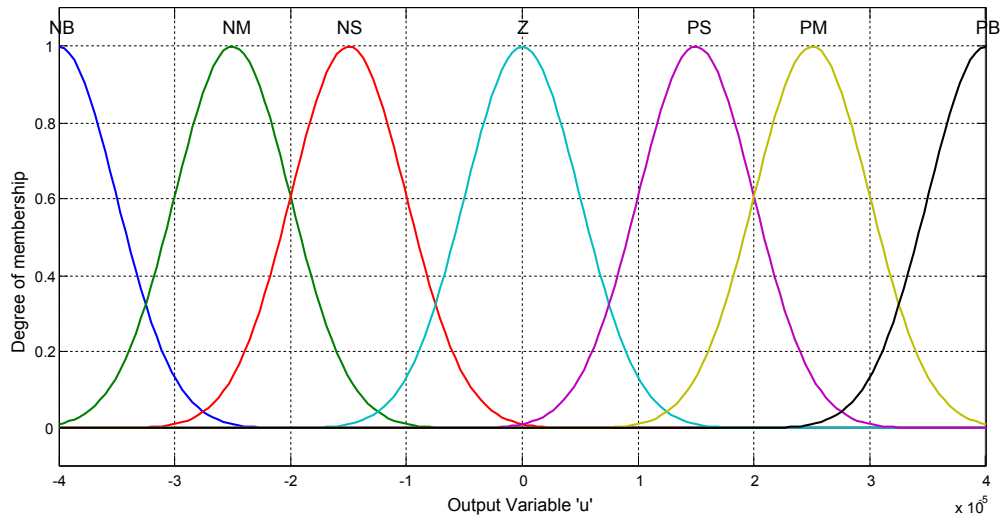

Fig. 11 – Membership functions of the control  $u$ .

flow feedback signal,  $uH_2(k)$  is the inferred change of duty ratio by fuzzy controller.

### Fuzzification

The fuzzification is the process of converting the crisp set into linguistic fuzzy sets using fuzzy membership function. The

Table 2 – Fuzzy control rules.

$\Delta uH_2$	$e$						
	NB	NM	NS	Z	PS	PM	PB
ce	NB	NB	NB	NB	NM	NS	Z
	NM	NB	NB	NM	NS	Z	PS
	MS	NB	NM	NS	Z	PS	PM
	Z	NM	NS	Z	PS	PM	PB
	PS	NM	NS	Z	PS	PM	PB
	PM	NS	Z	PS	PM	PB	PB
	PB	Z	PS	PM	PB	PB	PB

membership function is a curvature that describes each point of membership value in the input space [18]. Fuzzy rule base is the basic function of fuzzification (see Fig. 8).

The membership functions for inputs and output are Gaussian type. The membership functions for error, change of error and control are presents in Figs 9–11. The fuzzy domain for  $e$   $[-1, 1]$ ,  $e_c$  is  $[-0.5, 0.5]$ , and for  $u$  is  $[-4e^{-5}, 4e^{-5}]$ . In this paper, the output control  $u$  of the fuzzy controller is designed as  $qH_2$ , that is the input molar flow of hydrogen of the PEM fuel cell.

Seven uniformly distributed Gaussian membership functions are used for the fuzzification of the inputs. Each of the FLC input signals and output signals are fuzzy variables and are assigned seven linguistic variables, namely, NB, NM, NS, Z, PS, PM, and PB, which stand for negative big, negative medium, negative small, zero, positive small, positive medium and, positive big, respectively.

Fuzzy control rules are obtained from the behavior analysis of the PEMFC system. Because the rule-base represents the

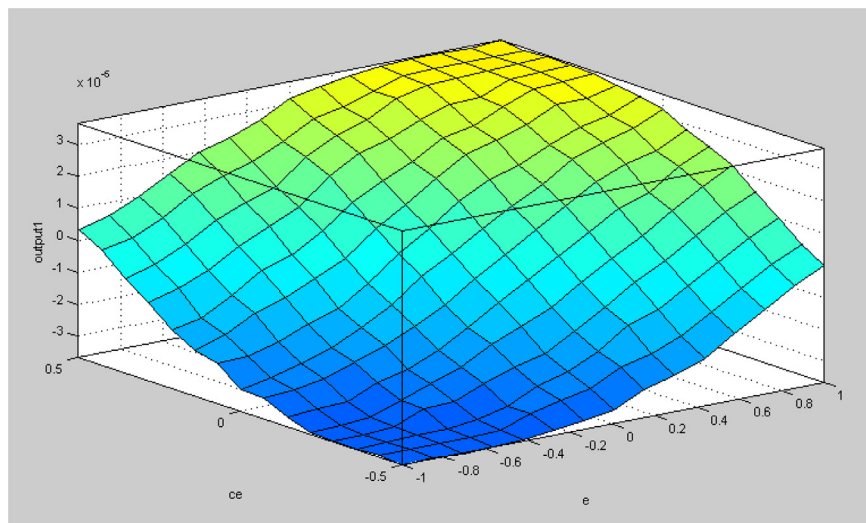

Fig. 12 – The control surface.

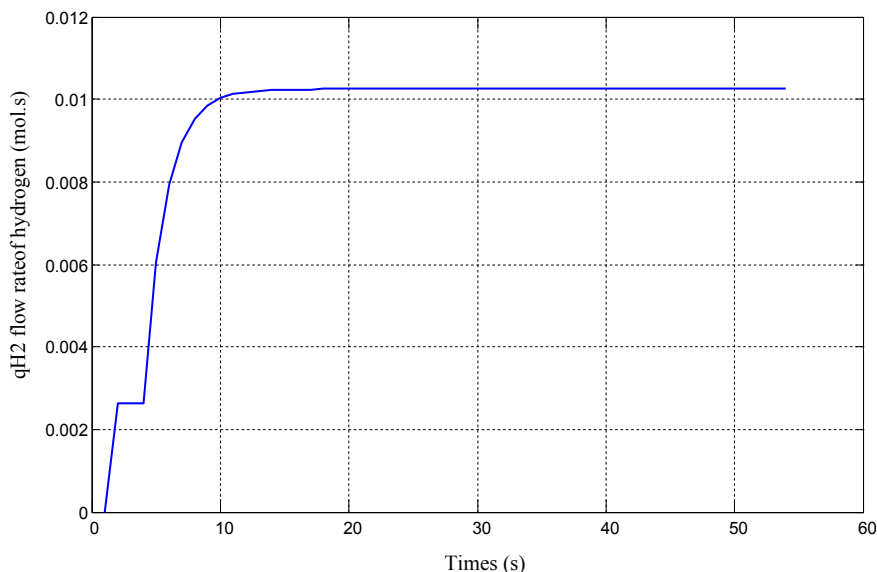

Fig. 13 – Hydrogen flow rate change without FLC.

intelligence of the controller, the formulations must be carefully considered. Correct use of control laws according to the operating conditions can greatly improve the system stability. The fuzzy rule base is a set of linguistic rules defined with IF-THEN conditions. For example fuzzy rules are:

If  $e(k)$  is NB and  $ce(k)$  is NB then  $\Delta u_{H_2}$  is NB;

If  $e(k)$  is NB and  $ce(k)$  is NM then  $\Delta u_{H_2}$  is NB;

.....

The rule base of the flow hydrogen controller has been listed in Table 2.

#### Inference engine

Fuzzy inference engine is an operating method that formulates a logical decision based on the fuzzy rule setting and transforms the fuzzy rule base into fuzzy linguistic output

[10]. Fuzzy linguistic descriptions are formal representations of systems made through fuzzy IF-THEN rules. They encode knowledge about a system in statements of the form: IF (a set of conditions) are satisfied THEN (a set of consequents) can be inferred.

Inference engine mainly consist of Fuzzy rule base and fuzzy implication sub blocks. The inputs are now fuzzified are fed to the inference engine and the rule base is then applied. The output fuzzy set are then identified using fuzzy implication method. MIN-MAX inference is employed in this paper.

#### Defuzzification

The last step in the FLC process is the defuzzification. These will have a number of rules that transform a number of variables into a fuzzy result, that is, the result is described in

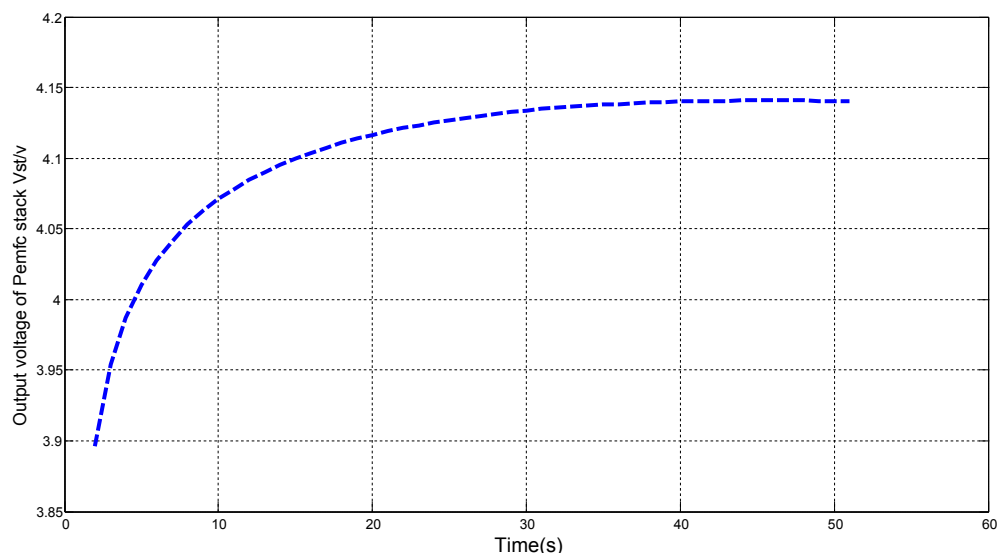

Fig. 14 – output voltage change without FLC.

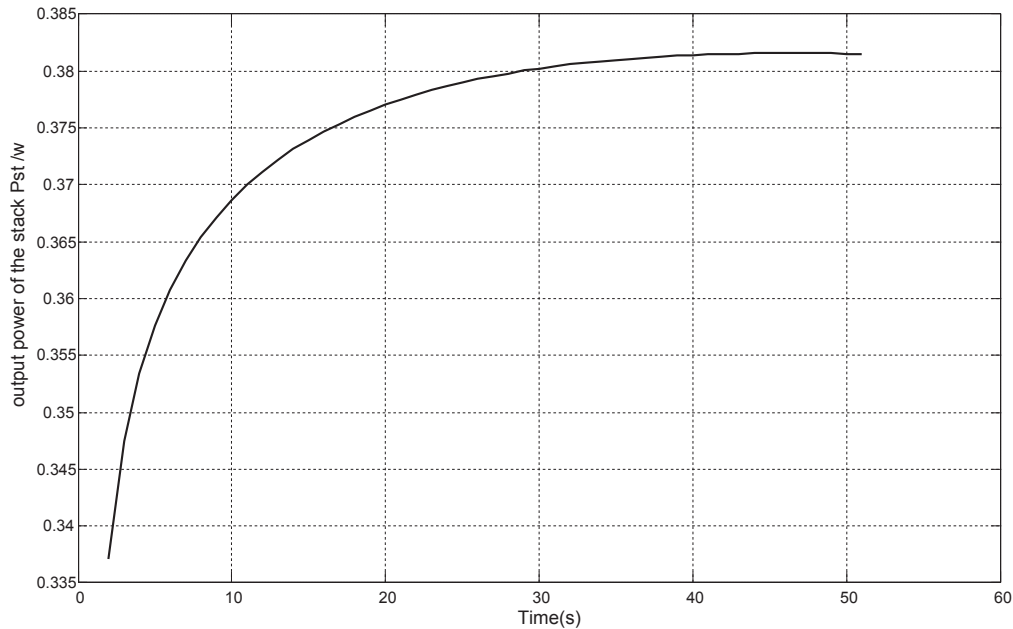

Fig. 15 – output power change without FLC.

terms of membership in fuzzy sets. Defuzzification is the process of mapping from a space of inferred fuzzy control actions to a space of non-fuzzy control actions. A defuzzification strategy aims to produce a non fuzzy control action that best represents the possibility distribution of the inferred fuzzy control actions. In real-time implementation of fuzzy logic control, the commonly used defuzzification strategies are the mean of maximum (MOM), the centre of Maximum (COM), the centre of area (COA) and the center of Gravity (COG) [19].

The centre of area (COA) is selected for the defuzzification process in this paper.

## Simulations results

In order to verify the validity of the proposed fuzzy controller, simulation operation was carried out in the MATLAB SIMULINK simulation platform [12]. The controller was designed to control the output power of the PEMFC by adjusting the hydrogen flow as shown in Fig. 6. Fig. 7 introduces the PEM fuel cell subsystem, the input signals are gases flow rate, and the outputs are voltage and power.

Fig. 8 shows the MATLAB Simulink of FLC architecture (Gain1 = 0.12, Gain2 = 1.12, and Gain3 =  $5.2e^{-5}$ ), where the output of the fuzzy controller is plotted against its two inputs.

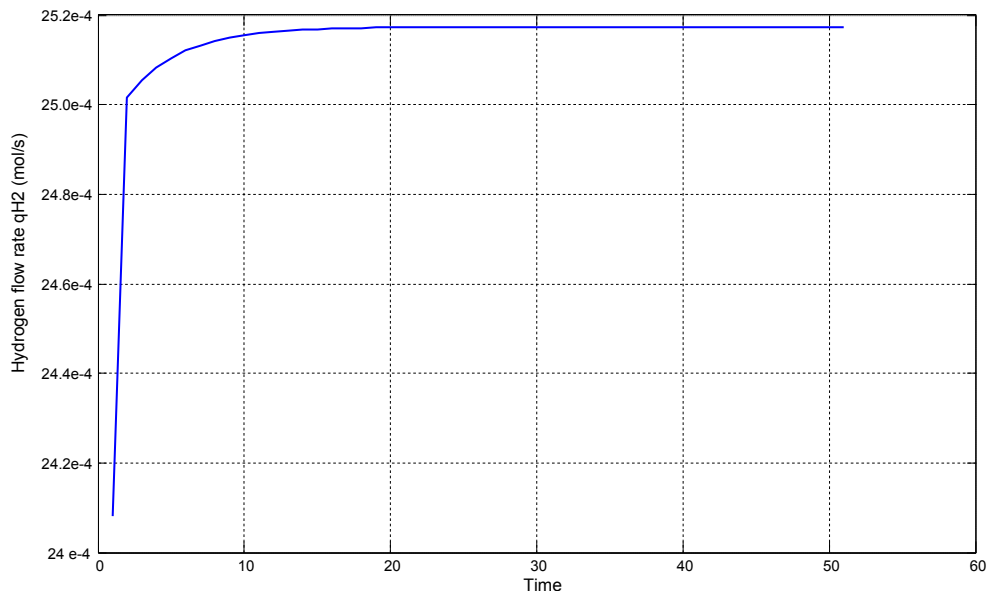

Fig. 16 – Hydrogen flow rate change with FLC.

The surface represents in a compact way all the information in FLC as shows in Fig. 12.

From Fig. 13, we can see that the gas reaction process requires a short time of delay to response. The output voltage of the PEM fuel cell cannot maintain a constant value generally, Figs. 14 and 15 show corresponding output response of the stack voltage and power of PEMFC system without control. It is also observed that the stack voltage and stack power of PEMFC changes accordingly during the power demands.

The output voltage of PEMFC system increases when the output power increases. This relation between power and the voltage of the FC system authenticates the reliability of the PEMFC model. The transient response of the PEMFC system voltage to the load changes varies according to the amount of power supplied by the PEMFC system as shown in Fig. 17. Fig. 18 presents the output power of PEM fuel cell with the reference power using FLC. It is clear that the controller success in making output power flow the variation of reference power.

Fig. 16 shows the Hydrogen flow rate change with FLC, it is evident that the hydrogen flow rate decreases with time as more and more hydrogen flow rate extracted from the PEMFC stack.

By comparing these figures with each other, it is clearly shown to us that the fuzzy controller proposed in this paper has the predomination of a faster time response and higher precision. The simulation results possess very similar characteristics and are as shown in Figs. 19, 20. The PEMFC voltage is back to a stable state in 40 s at 4.14 V and the output power stabilized in 0.382 W.

Finally, Robustness of proposed controller is proved by simulation of controller in noisy condition and the capability of proposed controller is compared with traditional PID. With the advance of technology, Fuzzy control system has become popular and reliable control system than traditional PID control system.

Fuzzy logic control system can handle the uncertainty of any process. PID controllers are widely used in the industrial

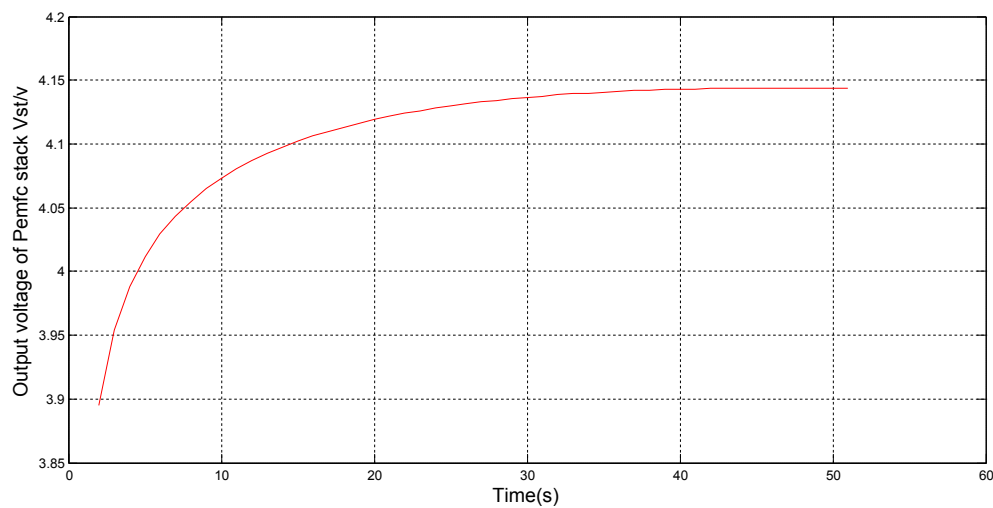

Fig. 17 – output voltage change with FLC.

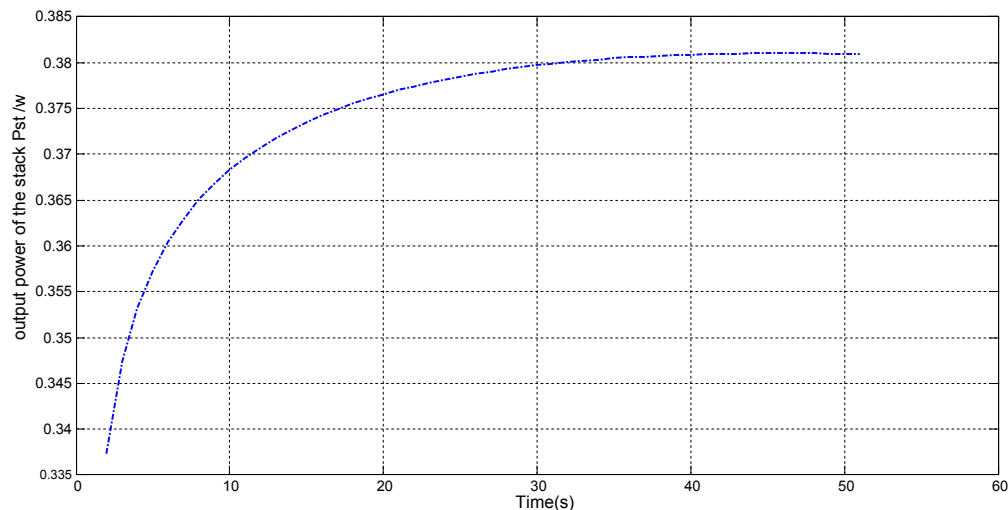

Fig. 18 – output power change with FLC.

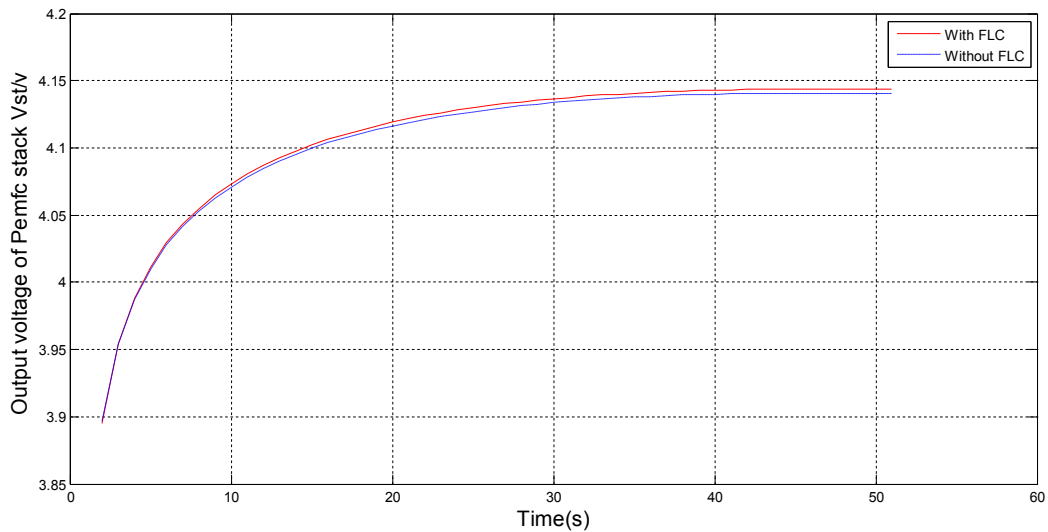

Fig. 19 – Comparison between output voltage change without FLC and change with FLC.

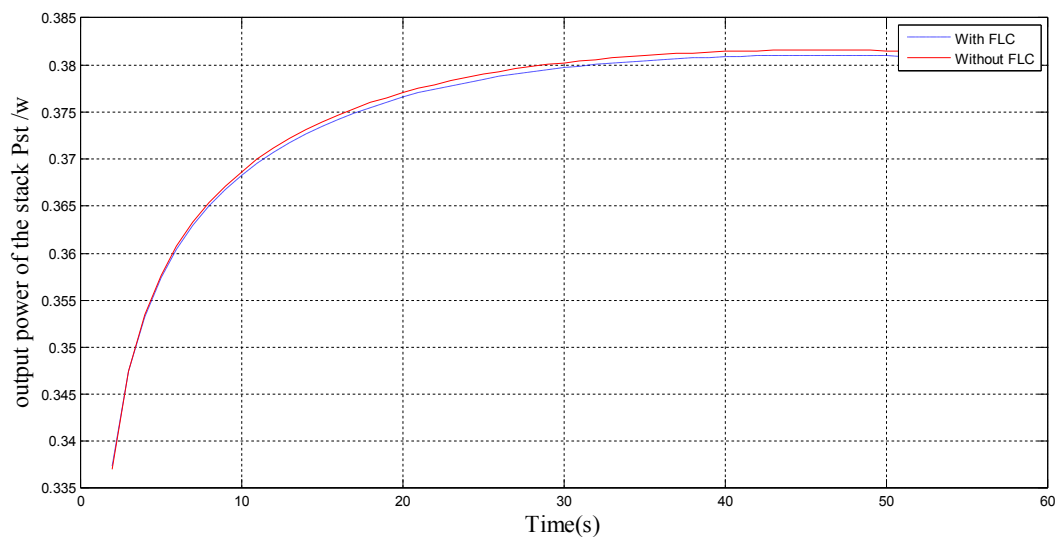

Fig. 20 – Comparison between output power change without FLC and change with FLC.

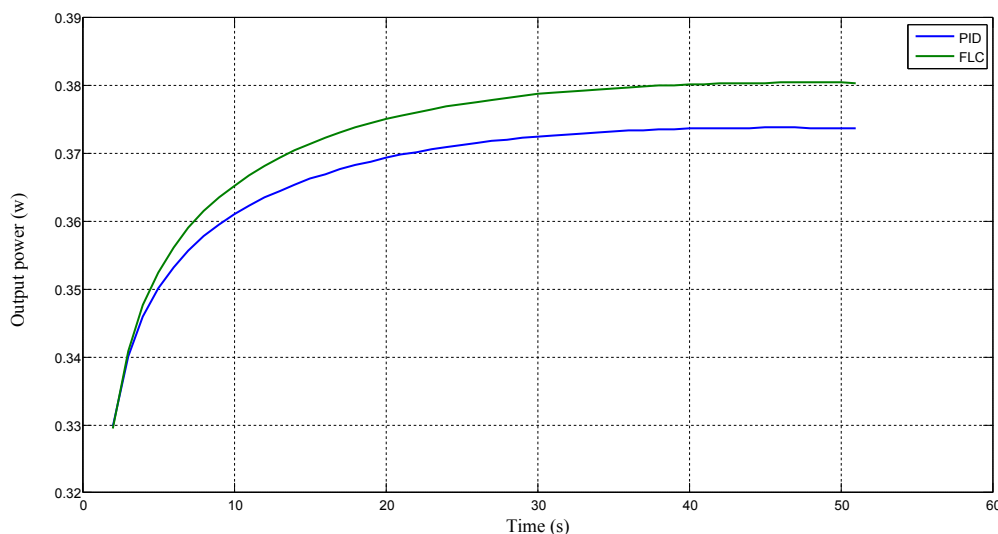

Fig. 21 – Output power curve for both PID and fuzzy logic control.

or any process control. But sometimes shows the poor performance [29].

In Fig. 21, system output curve has been depicted for both PID controller and fuzzy controller in the same time scale. For a specific input signal both controller has been tested in 60 s period to evaluate the performance. For both controller the output is smooth and don't have any overshoot. But for the rise time and settling time, fuzzy controller is more better than PID controller. Fuzzy controller has less rise time and settling time and system comes to the steady state very fast than conventional PID controller.

## Conclusions

In this paper a complete mathematical modeling and MATLAB SIMULINK model for the PEM fuel cell are developed and a control system, which includes either the FLC controller, is developed for controlling input gases flow rate. The simulation results show that the feasibility FLC with the main components; Fuzzification, fuzzy rule base, and Defuzzification are introduced also and applied to control input gases flow rate. The performance of the system is evaluated by comparing its performance using FLC. The response of output power using FLC is more accurate and better than without FLC. So the fuzzy controller gives better performance than PID controller.

## Acknowledgements

The authors gratefully acknowledge the substantial contributions of Dr. Mahmah B.

## REFERENCES

- [1] Benyahia N, Denoun H, Badji A, Zaouia M, Rekioua T, Benamrouche N, et al. MPPT controller for an interleaved boost dc-dc converter used in fuel cell electric vehicles. *Int J Hydrogen Energy* 2014;39(27):15196–205.
- [2] Kunusch C, Puleston PF, Mayosky MA, Riera J. Sliding mode strategy for PEM fuel cells stacks breathing control using a super-twisting algorithm. *IEEE Trans Control Syst Technol* 2009;17(1):167–74.
- [3] Riascos LAM, Pereira DD. Temperature in PEM fuel cells. *ABCMSym Ser Mechatronics* 2010;4:137–46.
- [4] Guilbert D, Gaillard A, N'Diaye A, Djerdir A. Energy efficiency and fault tolerance comparison of DC/DC converters topologies for fuel cell electric vehicles. In: *IEEE Transp Electrification Conf Expo Dearborn, USA: ITEC*; 16–19 June 2013.
- [5] Dixon JW, Contardo JM, Moran LAA. Fuzzy controlled active front-end rectifier with current harmonic filtering characteristics and minimum sensing variable. *IEEE Trans Power Electron* July 1999;14(4):724–9.
- [6] Rukonuzzaman M, Nakaoka. Fuzzy logic current controller for three-phase voltage source PWM-inverters. In: *Industry application Conference2*; 8-12 October 2000. p. 1163–9.
- [7] Benchouia N, Hadjadj Aouel E, Derghal A, Khochemane L, Mahmah B. Modeling and validation of PEM. *Fuel Cell Rev Ren Ener* 2013;16(2):265–77.
- [8] Benchouia N, Hadjadj Aouel E, Khochemane L, Mahmah B. Bond graph modeling approach development for fuel cell PEMFC systems. *Int J Hydrogen Energy* 2014;39(27):15224–31.
- [9] Uzunoglu M, Alam MS. Dynamic modeling, design, and simulation of a combined PEM fuel cell and ultracapacitor system for stand-alone residential applications. *IEEE Trans Energy Convers* 2006;21:767–75.
- [10] El-Sharkh MY, Rahman A, Alam MS, Byrne PC, ASakla A, Thomas T. A dynamic model for a stand-alone PEM fuel cell power plant for residential applications. *J Power Sources* 2004;139:199–204.
- [11] Mammam K, Chaker A. Fuzzy logic control of power of PEM fuel cell system for residential power generation. *J Electr Eng* 2009;60(6):328–34.
- [12] MATLAB SIMULINK, 7.7.0 ( 2008 Rb), license number 161051 september17. 2008.
- [13] Onar OC, Uzunoglu M, Alam MS. Dynamic modeling, design and simulation of a wind/fuel cell/ultra-capacitor-based hybrid power generation system. *J Power Sources* 2006;707–22.
- [14] Hua P, Cao GY, Zhu XJ, Hu M. *Int J Hydrogen Energy* 2010;35:9110–23.
- [15] Kisacikoglu MC, Uzunoglu M, Alam MS. Fuzzy logic control of a fuel cell/battery/ultra-capacitor hybrid vehicular power system, vehicle power and propulsion. *Int J Hydrogen Energy* 2009;34:1497–507.
- [16] Sakhare A, Davari A, Feliachi A. Fuzzy logic control of fuel cell for stand-alone and grid connection. *J Power Sources* 2004;135:165–76.
- [17] Erdinc O, Vural B, Uzunoglu M, Ates Y. Modeling and analysis of an FC/UC hybrid vehicular power system using a wavelet-fuzzy logic based load sharing and control algorithm. *Int J Hydrogen Energy* 2009;34:5223–33.
- [18] Rodriguez J, Lai JS, Peng Fang Z. Multilevel inverters: a survey of topologies, controls and applications. *IEEE Trans Industrial Electron* Aug 2002;49(4):724–38.
- [19] Zhan Y, Zhu J, Guo Y, Rodriguez A. An intelligent controller for PEM fuel cell power system based on double closed-loop control. In: *Australasian universities power engineering Conference M. Negnevinsky. Cd.. Hobart, Australia; September 25–18. 2005.*
- [20] Spiegel C. PEM modeling and simulation using matlab. Burlington, MA: Academic Press; 2008. p. 269–98.
- [21] Boddu R, Marupakula U, Summers B, Majumdar P. Development of bipolar plates with different flow channel configurations for fuel cells. *J Power Sources* 2009;189:1083–92.
- [22] Kaytakoglu S, Akyalm L. Optimization of parametric performance of a PEMFC. *Int J Hydrogen Energy* 2009;32(17):4418–23.
- [23] Riascos LAM, Pereira DD. Controlling operating temperature in PEM fuel cells. *ABCMSymposium Ser Mechatronics* 2010;4:137–46.
- [24] Nhivekar GS, Nirmale SS, Mudholker RR. Implementation of fuzzy logic control algorithm in embedded microcomputers for dedicated application. *Int J Eng, Sci Technol* 2011;4:276–83.
- [25] Corcau JI, Stoenescu E. Fuzzy logic controller as a power system stabilizer. *Int J Circuits Syst Signal Process* 2007;1(3):266–72.
- [26] Horiuchi J, Kishimoto M. Application of fuzzy control to industrial bioprocesses in Japan. *Fuzzy Sets Syst* 2002;1(128):117–24.
- [27] Mezzai N, Rekioua D, Rekioua T, Idjdarane K, Bacha S. Modeling of hybrid photovoltaic/wind/fuel cells power system. *Int J Hydrogen Energy* 12 September 2014;39(27):15158–68.

- [28] Mahmah B, M'Raoui A, Belhamel M, Benmoussa H. Experimental study and modelling of a fuel cell PEMFC fed directly with hydrogen/oxygen. In: 16th world hydrogen energy Conference (WHEC16) – Lyon France; 13–16 June 2006.
- [29] Gaurav, Kaur Amrit. Comparison between conventional PID and fuzzy logic controller for liquid flow control: performance evaluation of fuzzy logic and PID controller by using MATLAB/Simulink. *Int J Innovative Technol Explor Eng (IJITEE)* June 2012;1(1). ISSN: 2278-3075.